

## TECHNICAL DATA

Conveying capacity	System widths	Conveying speed
20.000 Eggs/h	350 mm	7 m / min.
30.000 Eggs/h	500 mm	7 m / min.
Drives	Gear motor power	Power supply
Front drive Intermediate drive Short drive	0,37 kW or 0,18 kW	230 / 400 V 50 Hz other voltages on request

## LAYOUT

Conveyor width [mm]			Conveying distance [mm]	Bend radius [mm]
Type 350	Type 500	Index		
350	500	A		
390	540	B		
750	1080	R i		
945	1350	R m		
1140	1620	R a		

Ascend and descend up to max. 60°:

1

Pivoting unit, continuously adjustable up to 50°.

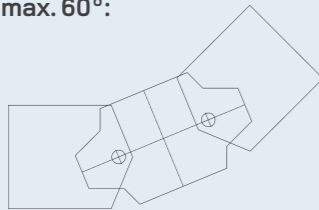

2

Fixed incline segments 60° (only possible with cover caps)

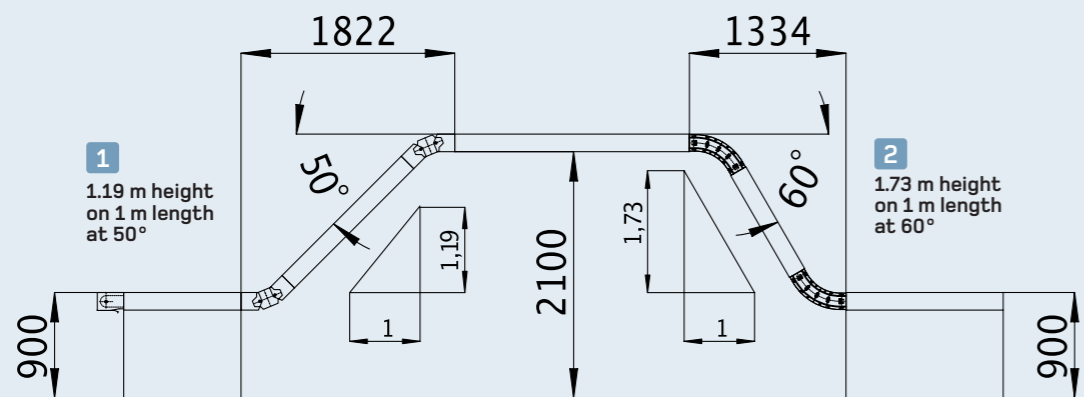
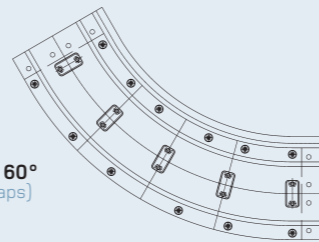

## SUITABLE COMPLEMENT



Cleaning Unit

Input Unit

Egg Counter

# LUBING

LUBING Maschinenfabrik GmbH & Co. KG

Lubingstraße 6 · 49406 Barnstorf

+49(0)54 42 - 9879-0

+49(0)54 42 - 9879-33

www.lubing.com · info@lubing.com

# LUBING

## STEEP CONVEYOR "CLIMBER" FOR THE EGG TRANSPORT UP TO 60°



# LUBING STEEP CONVEYOR "CLIMBER"

The steep conveyor „Climber“ makes it possible to overcome greatest differences in height in the smallest of spaces in conveyor systems: Up to 1.73 m height difference on 1 m length are possible. The conveyor chain with plastic tab elements is the core of the conveyor and enables inclines or declines of up to 60°.

The Climber works with two externally guided round link chains connected by cross bars. No support elements or guide elements are needed in the middle of the conveyor which divide or divert the egg flow.

All components have been derived from the LUBING curve conveyor system and have been specially developed to meet the needs of farms with floor or aviary housing.

The well-known and proven standard elements such as drives, bends, pivoting units, telescopes for lift systems and intermediate drives for large conveyor sections can all be integrated without transfer points.

Ask us for possibilities to create a tailor-made individual solution for you.

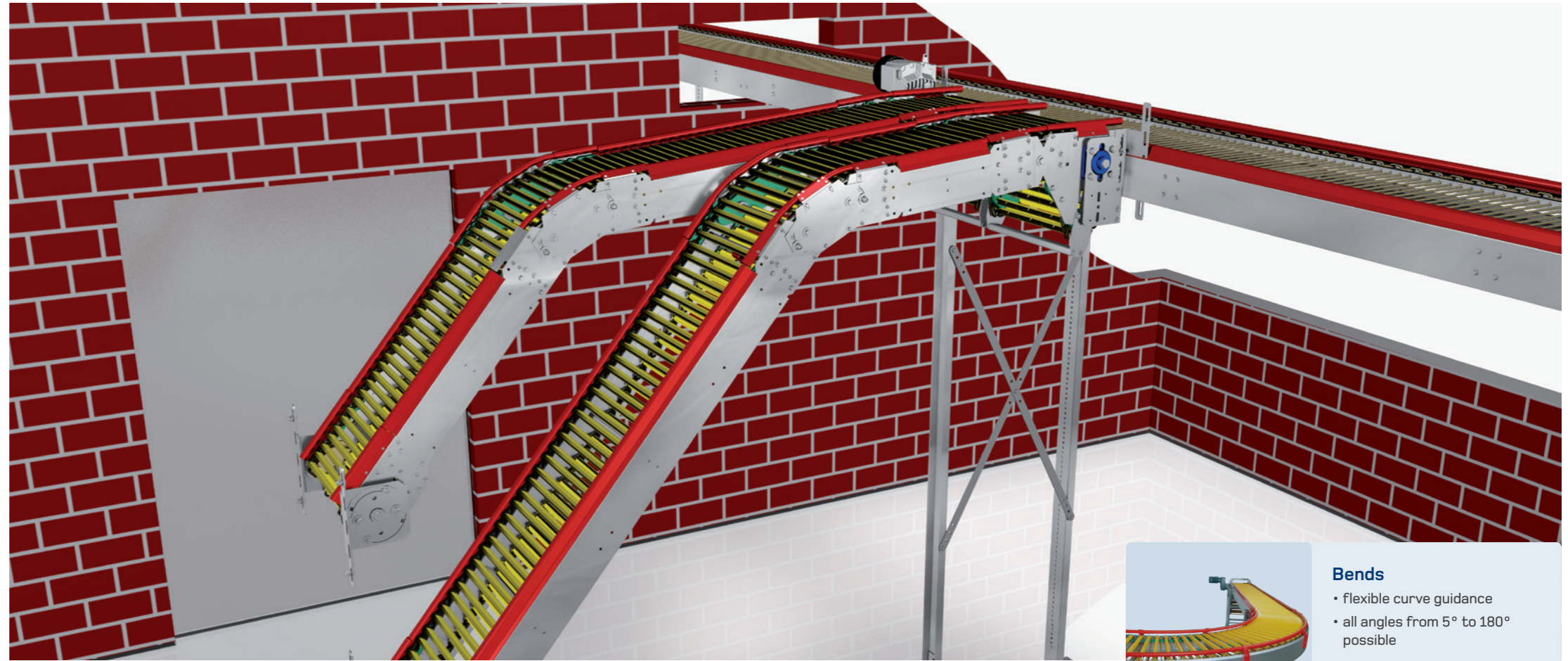

#### Bends

- flexible curve guidance
- all angles from 5° to 180° possible

## ADVANTAGES

### OF THE LUBING „CLIMBER“ STEEP CONVEYORS

- gradients or inclines up to 60°
- compatible with all curved conveyor elements
- highest functional reliability due to two externally guided round link chains
- no centrally placed support or guide elements required: No interfering contours on the conveyor line
- the individually replaceable tab elements made of high-quality plastic ensure the safe position of all egg sizes in the transition from level to slope
- in the inner radius of the bends, the egg is slightly lifted by the tab elements. The special shape of the attachment elements ensures gentle egg handling

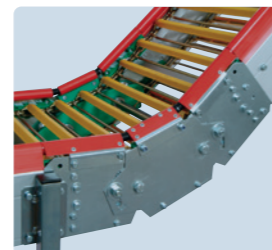

#### Pivoting unit incline

- steplessly adjustable up to 50° gradient
- flexible and continuously adjustable side plates



#### Pivoting unit decline

- steplessly adjustable up to 50° slope
- flexible and continuously adjustable side plates

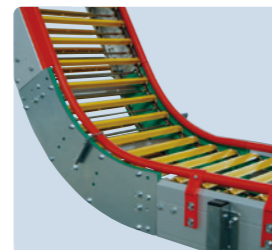

#### Slope segment descend 60°

- fixed preset unit for 60° gradient
- cover caps required



#### Slope segment ascent 60°

- fixed preset unit for 60° slope
- cover caps required



#### Trampoline transfer

- special net for transfer into the conveyor chain
- flexible, soft transfer for maximum gentle egg handling



#### End units

- simple and safe deflection of the conveyor chain at the end of the line
- special deflection rollers for highest functional reliability



#### Connecting parts

- available in 1-meter, 2-meter and 3-meter lengths



#### Front drives

- front drive of the conveyor chain with 0.37 or 0.18 kW
- with integrated tensioning element for correct chain tensioning

# LUBING

Further information under [WWW.LUBING.COM](http://WWW.LUBING.COM)